

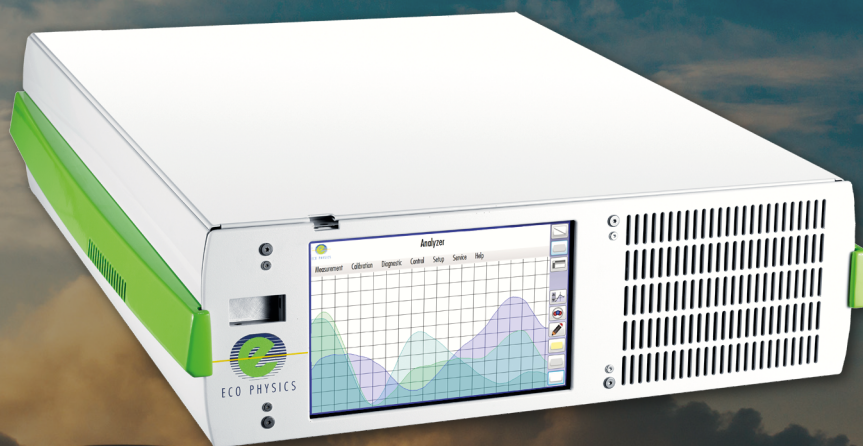

# ECO PHYSICS nCLD 822 CMhr

## APPLICATION EXAMPLES

- Burners and boilers
- Manufacturers of gas turbines
- Certification and calibration
- DeNOx Plants and SCR
- Refining of fuels and lubricants
- Assessment of ammonia slip
- Research and development



**The nCLD 822 CMhr analyzer is the next generation in high precision nitrogen oxide measurement. Unique in speed and reliability, the nCLD 822 CMhr is modular designed and capable of sequentially measuring NO, NO<sub>2</sub>, NO<sub>x</sub>, NH<sub>3</sub> and NO<sub>x</sub>-Amines from hot and humid gas sources without additional cooler. The new and intuitive graphical user interface "GUI" also individually displays and connects to other instruments' data.**

### Measurement of:

- NO
- NO<sub>2</sub>
- NO<sub>x</sub>
- NH<sub>3</sub>
- NO<sub>x</sub>-Amines

### Straight From the Source

The nCLD 822 CMhr includes everything that is needed for measuring NO, NO<sub>2</sub>, NO<sub>x</sub>, NH<sub>3</sub> and NO<sub>x</sub>-Amines in unpreconditioned gas samples. The fully revised detector-block, the enhanced gas flow paths and the improved pressure as well as temperature independence of the nCLD 800 Series instruments allow for even lower detection limits. The integrated hot tubing enables the instrument to analyze hot and moist sources and the electro-mechanical bypass system balances out pressure variations occurring in the sample flow. Furthermore, the analyzer is adaptable to numerous non-standardized applications. Calibration of the unit runs quickly and automatically.

### User Friendliness with "GUI"

The new touch sensitive graphical user interface "GUI" enables the user to individually adjust the instrument operation and data management according to his/her needs and applications. The bright 8" monitor gives a clear overview and allows numerical and graphical display of values. Multiple digital in- and outputs guarantee a maximal connectivity for your remote operation, control and maintenance of the nCLD 822 CMhr, ensuring unsurpassed precision and reliability.

### Compact, Modular and Intelligent!

The nCLD 822 CMhr is manufactured in a new compact and modular layout, in which each essential component of the chemiluminescence analyzer hosts its own CPU and interacts with other CPUs by BUS-communication. This assembly increases accessibility and serviceability by reducing wiring and piping. The measurement principle will conform to the standard method for NO<sub>x</sub>-detection in stationary source emissions (EN 15267).

- Rapid system integration and rack mounting
- Compact and modular design
- Virtually maintenance free even in continuous operation
- Four freely selectable measuring ranges

Graphical user interface "GUI" for individual analyzer operation and data management

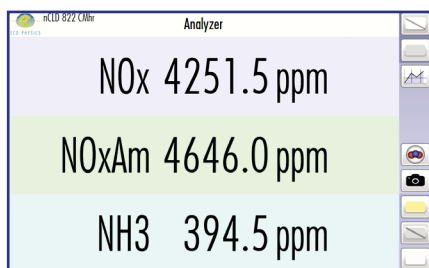

**Measurably better**

# SPECIFICATIONS

# nCLD 822 CMhr

Analyzer type	dual chamber CLD with cooled PMT for measurement of NO, NO <sub>2</sub> , NO <sub>x</sub> , NH <sub>3</sub> and NO <sub>x</sub> -Amines
Measuring ranges	four freely selectable ranges from 5 - 5'000 ppm
Min. detectable concentration*	0.12 ppm
Noise at zero point (1σ)*	0.06 ppm
Lag time	<3 sec
Rise time (0 - 90%)	<1 sec
Temperature range	5 - 40 °C
Humidity tolerance	5 - 95% rel. h (non-condensing, ambient air and sample gas)
Sample flow rate	1.0 l/min
Input pressure	600 - 1'200 mbar abs.
Dry air use for O <sub>3</sub> generator	internally generated (no external supply gas required)

Power required	350 VA (incl. membrane pump and ozone scrubber)
Supply voltage	100 - 240 V/50 - 60 Hz
Interface	USB(3x), HDMI, Bluetooth, RS232 (w/o 9pin connector), LAN, WLAN
Dimensions	height: 133 mm (5¼ ") width: 450 mm (19 ") with molding: 495 mm depth: 540 mm (21.2 ")
Weight	23 kg (51 lb)
Delivery includes	nCLD 822 CMhr analyzer, power cable, FTDI-RS232-USB cable, USB-LAN adapter, HDMI adapter
Standard	nCLD 822 CMhr <ul style="list-style-type: none"> <li>• <b>C</b> - catalyst converter</li> <li>• <b>M</b> - metal converter</li> <li>• <b>h</b> - hot tubing</li> <li>• <b>r</b> - electro-mechanical pressure regulation</li> </ul>
Options	<ul style="list-style-type: none"> <li>• USB-RS232 9pin connector</li> <li>• 0 - 10 V</li> <li>• 4 - 20 mA into 500 Ω max.</li> </ul>
	Analog output (External Box)

© ECO PHYSICS AG, Switzerland 2020-1/2

# FLOW DIAGRAM

\*Depending on filter setting  
Connectivity properties are country-specific  
ECO PHYSICS reserves the right to change these specifications without notice.

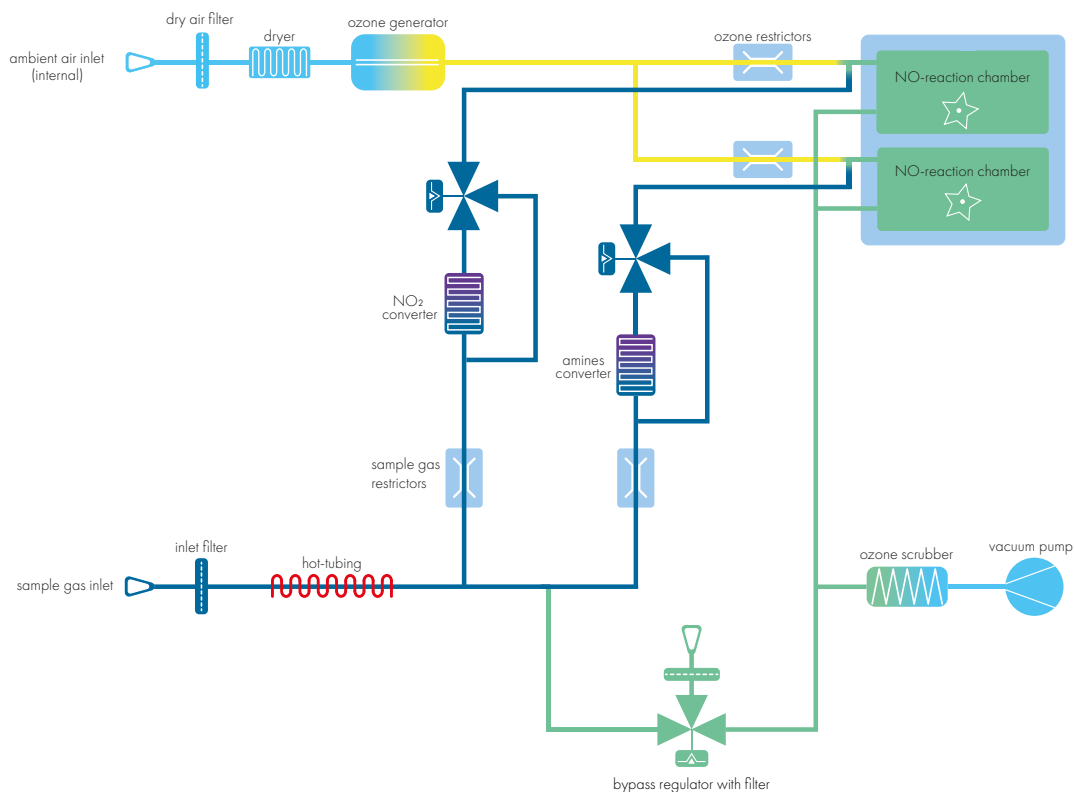

ECO PHYSICS

ECO PHYSICS AG · POB · CH-8635 DUERNTEN · TEL. +41 55 220 22 22 · FAX +41 55 220 22 55 · E-MAIL INFO@ECOPHYSICS.COM

WWW.ECOPHYSICS.COM