

Nephelometric system based on ISO 7027 for the automatic and continuous measurement of turbidity in pure water in water steam cycles.

Monitor AMI Turbiwell Power

- Non-contact turbidimeter: System optics is not in direct contact with sample, no fouling on optical surfaces.
- Complete system including optoelectronics, sample chamber, turbidimeter and sample flow meter mounted on stainless steel panel.
- Suitable for the measurement of other liquids of which the turbidity correlates with the concentration of a suspended solid or an emulsified liquid, e.g. an oil water emulsion.
- Measuring range: 0.000 - 200.0 FNU/NTU
Automatic range switching.
- Precision: ± 0.003 FNU/NTU or 1% of reading.
- Manual or automated draining of the sample chamber.
- Easy user menus in English, German, French and Spanish.
Simple programming of all parameters by keypad.
- Electronic record of major process events and calibration data.
- Real-time clock for time stamp in data logs and for automated functions.
- Data logger for 1'500 data records stored at selectable intervals.
- Big back-lit LCD display for the reading of all measured values and status information simultaneously.
- Measurement values are available as analog output signals.
- Potential-free alarm contact as summary alarm indication for programmable alarm values and for instrument faults.
- Input for potential-free contact to freeze the measuring value or to interrupt control in automated installations (hold function or remote-off).
- Factory tested, ready for installation and operation.

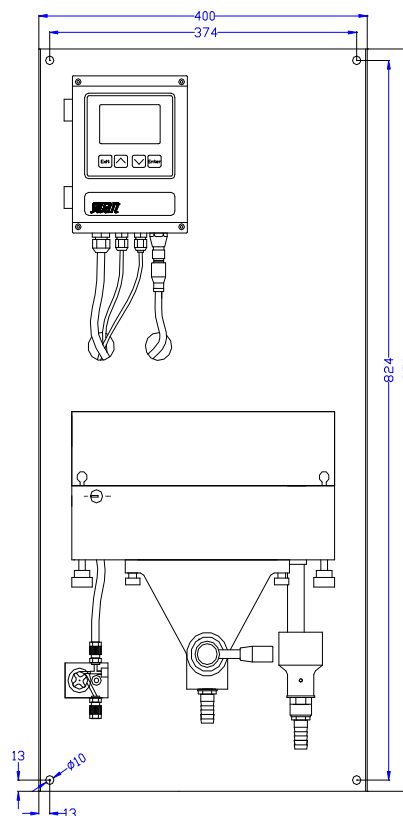

Monitor AMI Turbiwell on steel panel with flow meter.

Further options:

- Turbidity verification kits
(Low or High FNU for dry verification)

| Order Nr. | Monitor AMI Turbiwell Power | A-25.411.605.1 |
|-----------|---|----------------|
| | Monitor AMI Turbiwell Power; Auto-drain | A-25.411.605.2 |
| Option: | <input type="checkbox"/> 3 rd current signal output (0/4 – 20mA) | A-81.420.050 |
| | <input type="checkbox"/> Profibus DP & Modbus RTU interface (RS-485) | A-81.420.020 |
| | <input type="checkbox"/> USB interface | A-81.420.042 |
| | <input type="checkbox"/> HART interface | A-81.420.060 |

Turbidimeter System

Nephelometer according to ISO 7027

Measuring range: 0.000 to 200.0FNU/NTU
Precision: ± 0.003 FNU/NTU or ± 1%, whichever is greater

Two-part turbidimeter body made of PETP with drain valve. Heated optics to avoid condensation.

Easy cleaning of sample compartment.

Factory calibrated with Formazine.

Possibility to detect oil in pure water. Restrictions do apply.

Sample flow measurement with digital Swan sample flow sensor.

Transmitter Specifications and Functionality

Electronics case: Aluminum
Protection degree: IP 66 / NEMA 4X
Display: backlit LCD, 75 x 45 mm
Electrical connectors: screw clamps
Ambient temperature: -10 to +50 °C
Limit range of operation: -25 to +65 °C
Storage and transport: -30 to +85 °C
Humidity: 10 to 90 % relative, non condensing

Power supply
Voltage: 100 - 240 VAC (± 10 %), 50/60 Hz (± 5 %) or 24 VDC (± 10 %)
Power consumption: max. 30 VA

Operation
Easy operation based on separate menus for "Messages", "Diagnostics", "Maintenance", "Operation" and "Installation".
Separate, menu specific password protection.

Display of process value, alarm status and time during operation.

Storage of event log, alarm log and calibration history.

Storage of the last 1'500 data records in logger with selectable time interval.

Real-time clock with calendar
For action time stamp and preprogrammed actions.

Safety features
No data loss after power failure, all data is saved in non-volatile memory. Over-voltage protection of in- and outputs.
Galvanic separation of measuring inputs and signal outputs.

Electrical Connection Scheme

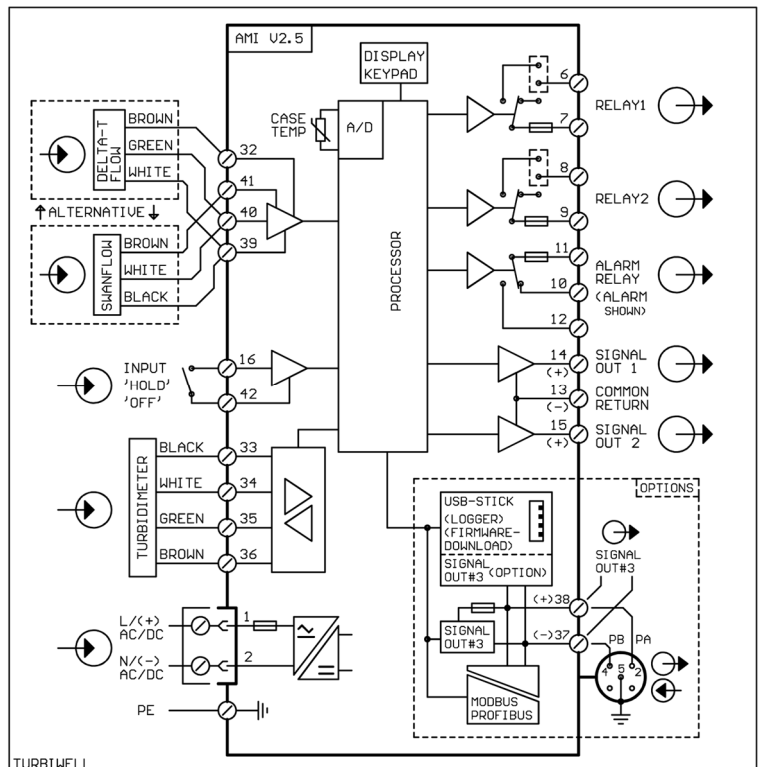

Transmitter temperature monitoring
With programmable high/low alarm limits.

1 Alarm relay
One potential free contact for summary alarm indication for programmable alarm values and instrument errors.
Maximum load: 1A / 250 VAC

1 Input
One input for potential-free contact. Programmable hold or remote off function.

2 Relay outputs
Two potential-free contacts program-able as limit switches for measuring values, controllers or timer with automatic hold function.
Rated load: 1A / 250 VAC

2 Signal outputs (3rd as option)
Two programmable signal outputs for measured values (freely scalable, linear or bilinear) or as continuous control output (control parameters programmable) as current source. 3rd signal output selectable as current source or current sink.
Current loop: 0/4 - 20 mA
Maximum burden: 510 Ω

Control functions
Relays or current outputs programmable for 1 or 2 pulse dosing pumps, solenoid valves or for one motor valve.
Programmable P, PI, PID or PD control parameters.

1 Communication interface (option)
- RS485 interface (galvanically separated) with Fieldbus protocol Modbus RTU or Profibus DP
- 3rd Signal output
- USB interface
- HART interface

Sample and Monitor Data

Sample conditions
Flow rate: approx. 20-60l/h
Temperature: up to 40 °C
Sample temperature max. 5°C over ambient temperature
Outlet pressure: pressure free, atmospheric drain

Sample connections
Inlet: Serto, 6mm
Drain: Ø 16 mm, tubing 15 x 20 mm

Panel
Dimensions: 400 x 850 x 200 mm
Material: stainless steel
Weight: 14.0 kg